



INTECH SOLUTIONS

Expansion Joint Covers | Architectural louvers | Grills | Sun controls



INTECH - Building Products

Intech Solutions have been in the field of Architectural and interior products /service for over 19 years, during which time we served several reputed architects, PMC's, builders and clients.

Our solutions are aesthetic, intelligent and seamlessly synergistic with the vision of the architecture. By balancing the look and feel with usability and functionality, we deliver inspiring solutions that strike the right chord and capture your vision in reality.

We Intech Solutions are experts at creating advanced products that solve difficult problems in today's fast-changing world. Our team of skilled engineers and designers are motivated and deliver top-quality results. By putting the user at the center of our design process and using the latest technology available, we make products that help both businesses and individuals succeed.

Welcome to a world where business meets excellence, passion meets commitment and focus meets you.... welcome to Intech Solutions .

Products by INTECH:

- **Expansion Joint Covers**
- **Architectural Louvers**
- **Architectural Grills**
- **Sun Controls**

INTECH - Expansion Joint Covers

1. Protect Your Infrastructure with Expansion Joint Covers: Our company offers top-of-the-line expansion joint covers that provide essential protection for your infrastructure. Designed with durability and performance in mind, our covers ensure the longevity of your structures, preventing costly damage caused by expansion and contraction.

2. Seamless Integration and Aesthetically Pleasing Solutions: Our expansion joint covers seamlessly integrate with the architectural design of your building, delivering both functionality and aesthetic appeal. With a wide range of customizable options available, we guarantee a solution that complements the overall look and feel of your space.

3. Unparalleled Performance in Diverse Environments: Whether you require expansion joint covers for commercial buildings, industrial facilities, or transportation infrastructure, our products are engineered to perform in various environments. From extreme temperatures and heavy foot traffic to seismic activity, our covers excel in providing reliable protection.

4. Enhanced Safety and Reduced Maintenance: Our expansion joint covers prioritize safety by minimizing tripping hazards and ensuring a smooth transition between different floor surfaces. By effectively sealing gaps and joints, they also prevent the infiltration of dust, moisture, and other debris, reducing maintenance efforts and costs.

5. Compliance with Industry Standards: Our expansion joint covers meet and exceed industry standards for quality, safety, and performance. Rest assured that our products are manufactured using the highest quality materials and undergo rigorous testing to ensure their reliability and adherence to regulatory requirements.

6. Proven Track Record and Satisfied Clients: With a solid track record of successful projects and satisfied clients, we have earned a reputation for excellence in the industry. Our portfolio showcases a diverse range of projects where our expansion joint covers have delivered outstanding performance and customer satisfaction.

INTERIOR FLOOR JOINT SYSTEMS

INS GF Series

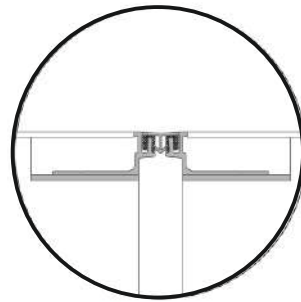

Floor to Floor

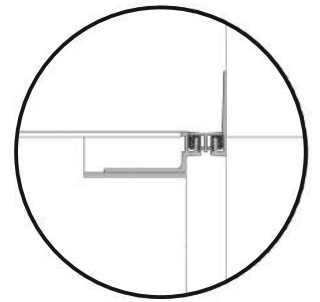

Floor to Wall

INTERIOR FLOOR JOINT SYSTEMS

INS FF Series

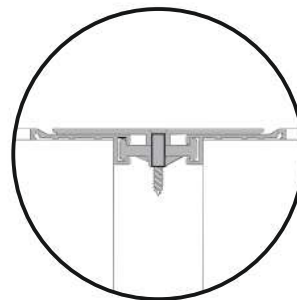

Floor to Floor

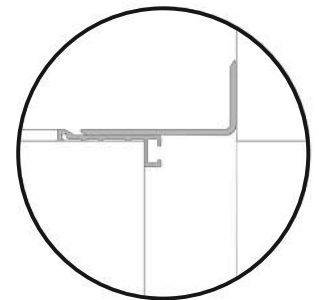

Floor to Wall

INTERIOR FLOOR,WALL,CEILING JOINT SYSTEMS

INS PL Series

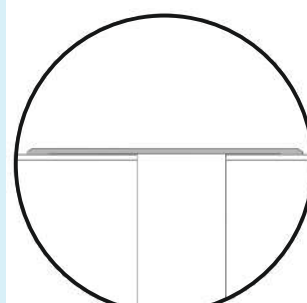

Floor to Floor

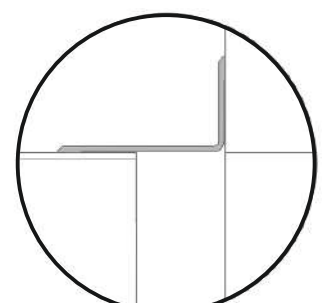

Floor to Wall

INTERIOR WALL + CEILING COVER JOINT SYSTEMS

INS SP Series

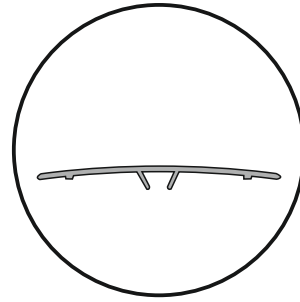
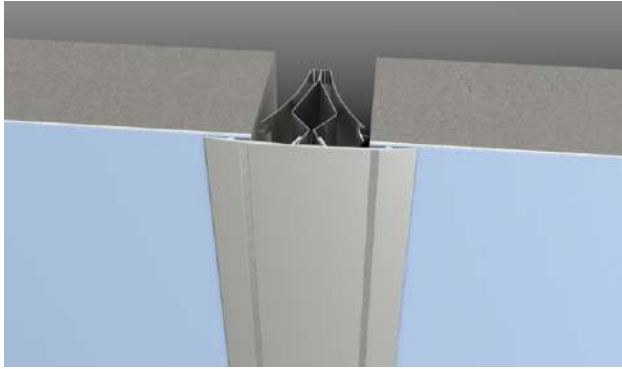

Wall to Wall

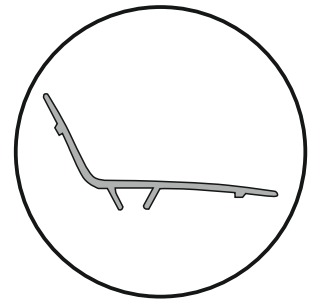

Corner Wall

FACADE + INTERIOR WALL COVER JOINT SYSTEMS

INS CL,CLE Series

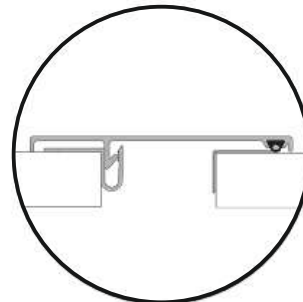

Wall to Wall

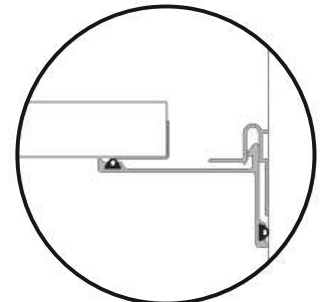

Corner Wall

INTERIOR + EXTERIOR COVER JOINT SYSTEMS

INS PTW Series

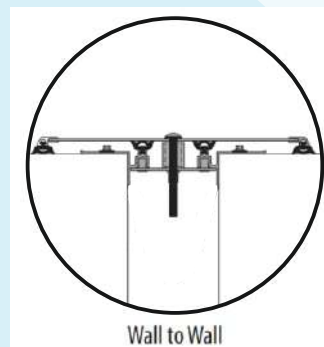

Wall to Wall

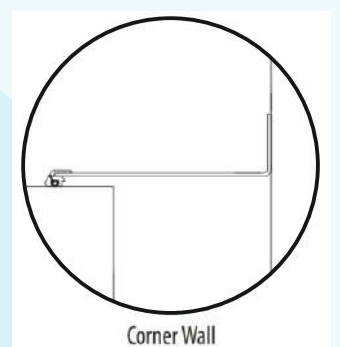

Corner Wall

EXTERIOR FLOOR + WALL COVER JOINT SYSTEMS

INS V Series

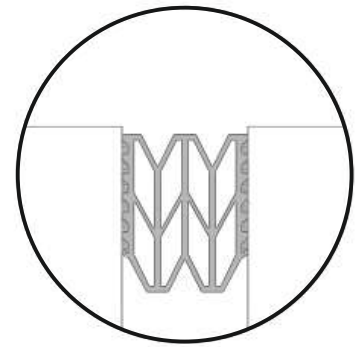
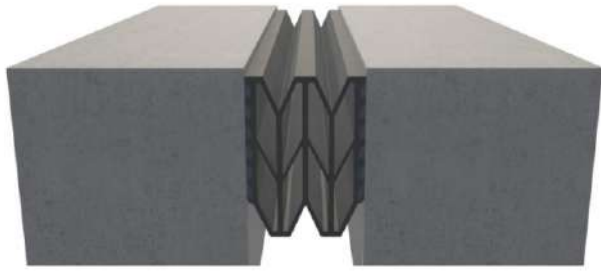

Floor to Floor

EXTERIOR FLOOR + TRAFFIC GRADE JOINT SYSTEMS

INS T Series

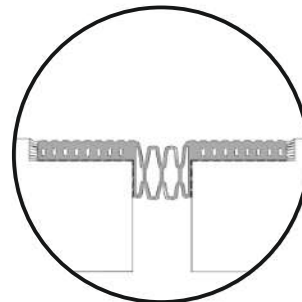
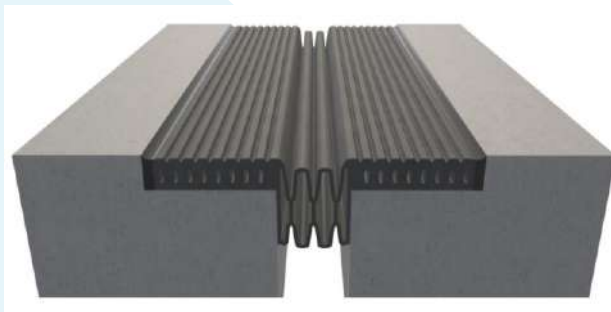

Floor to Floor

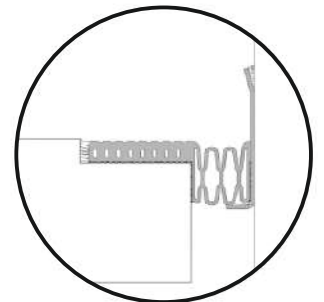

Floor to Wall

ROOF COVER SYSTEMS

INS RF Series

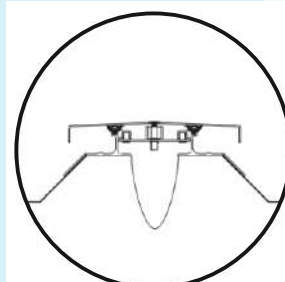

Floor to Floor



Floor to Wall

INTECH - Architectural Louvers and Grilles

1. Enhance Your Space with Aluminium Louvers and Grilles:

Our high-quality aluminium louvers are designed to add a touch of elegance and functionality to any space. Whether it's for a commercial building, residential property, or outdoor area, our louvers provide the perfect balance of aesthetics and practicality.

2. Customizable Aluminium Louvers for Your Unique Needs:

At INTECH SOLUTIONS, we understand that every project is unique. That's why our aluminium louvers are fully customizable to meet your specific requirements. From size and shape to color and finish, we offer a range of options to ensure your louvers perfectly complement your space.

3. Durable and Weather-Resistant:

Constructed from premium-grade aluminium, our louvers are built to last. They are highly durable and resistant to various weather conditions, including rain, wind, and UV rays. This makes them a reliable choice for both indoor and outdoor applications.

4. Low-Maintenance Solution for Hassle-Free Ownership:

Our aluminium louvers are engineered for low maintenance, ensuring a hassle-free ownership experience. They are resistant to rust, corrosion, and fading, requiring minimal cleaning and upkeep. Enjoy the benefits of stylish and functional louvers without the stress of constant maintenance.

5. Reliable Partner for Your Louver Needs:

When you choose INTECH SOLUTIONS, you're not just purchasing louvers – you're partnering with a trusted and reliable company. We offer professional guidance throughout the process, from design consultation to installation support. Your satisfaction is our top priority.

6. Architectural Grills and Suncontrols:

Our integrated solutions offer a seamless blend of design and performance, allowing you to achieve your vision while maximizing functionality. Whether you're seeking sleek and minimalist grills or dynamic suncontrol systems, we have the expertise and craftsmanship to bring your ideas to life.

Transform your space with our premium aluminium louvers. Contact us today for a personalized solution that meets your design aspirations and functional requirements.

Architectural Louvers

All louvers let air get into buildings, but the problem is they also let rain in. That's why our aluminium louvers are fully customizable resistant to various weather conditions, including rain, wind, and Sun light.



Louver screens can be custom designed to respond to external conditions, maximise airflow, prioritise weather protection, reduce noise, and even offer high security.

We encourage you to carefully consider exactly what you want your louver system to achieve.

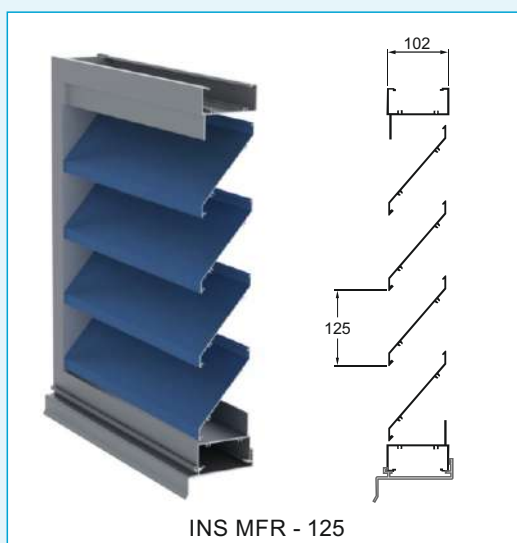

INS MFR - 125



INS RD - 50

All commercial and industrial buildings require louvers to provide ventilation, rain defence or screening.



Linear sunshades include horizontal and vertical applications and are good for shading East and West elevations, where low sun angles make sun control challenging.

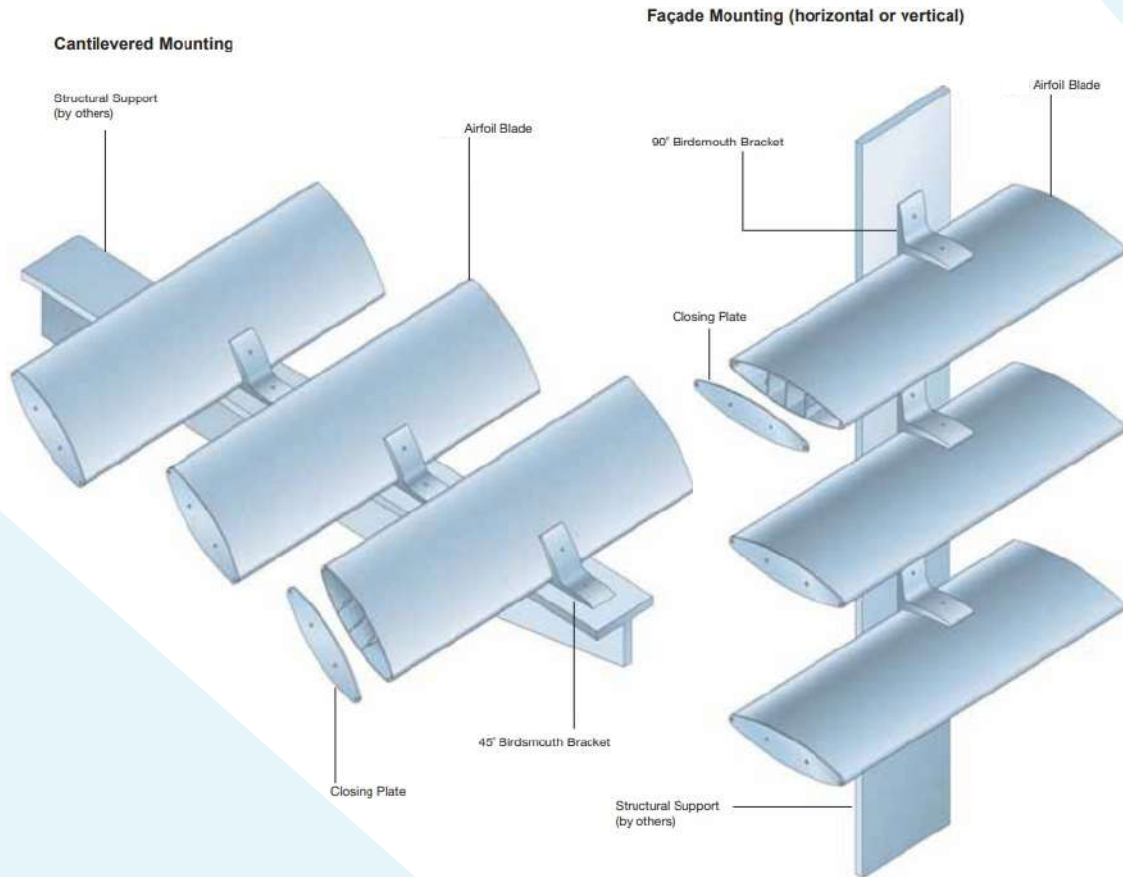

A good solar-shading system makes people in a building more comfortable and helps save energy by reducing the need for cooling. Shading elements and screens are often used in building designs to make them look modern and stylish. We committed to making high-quality sunscreens that are carefully crafted and designed to meet the specific requirements of each project. Our sunscreens are also certified to meet Standards.

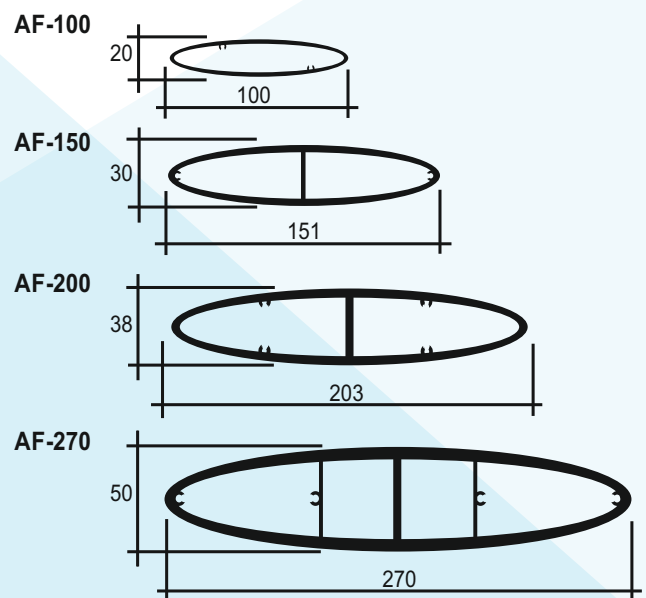





INTECH SOLUTIONS

Contact Us

📍 No. 5 / 2, Munirathinam Street, Ayyavu Colony, Aminjikarai,
Chennai - 600 029.

☎ +91 44 2374 0850 ✉ office@intechsolutions.co.in 🌐 www.intechsolutions.co.in
+91 72 9995 6991

